

CITY of SAN DIMAS STANDARD DRAWING

ENCLOSURE FOR SINGLE BINS

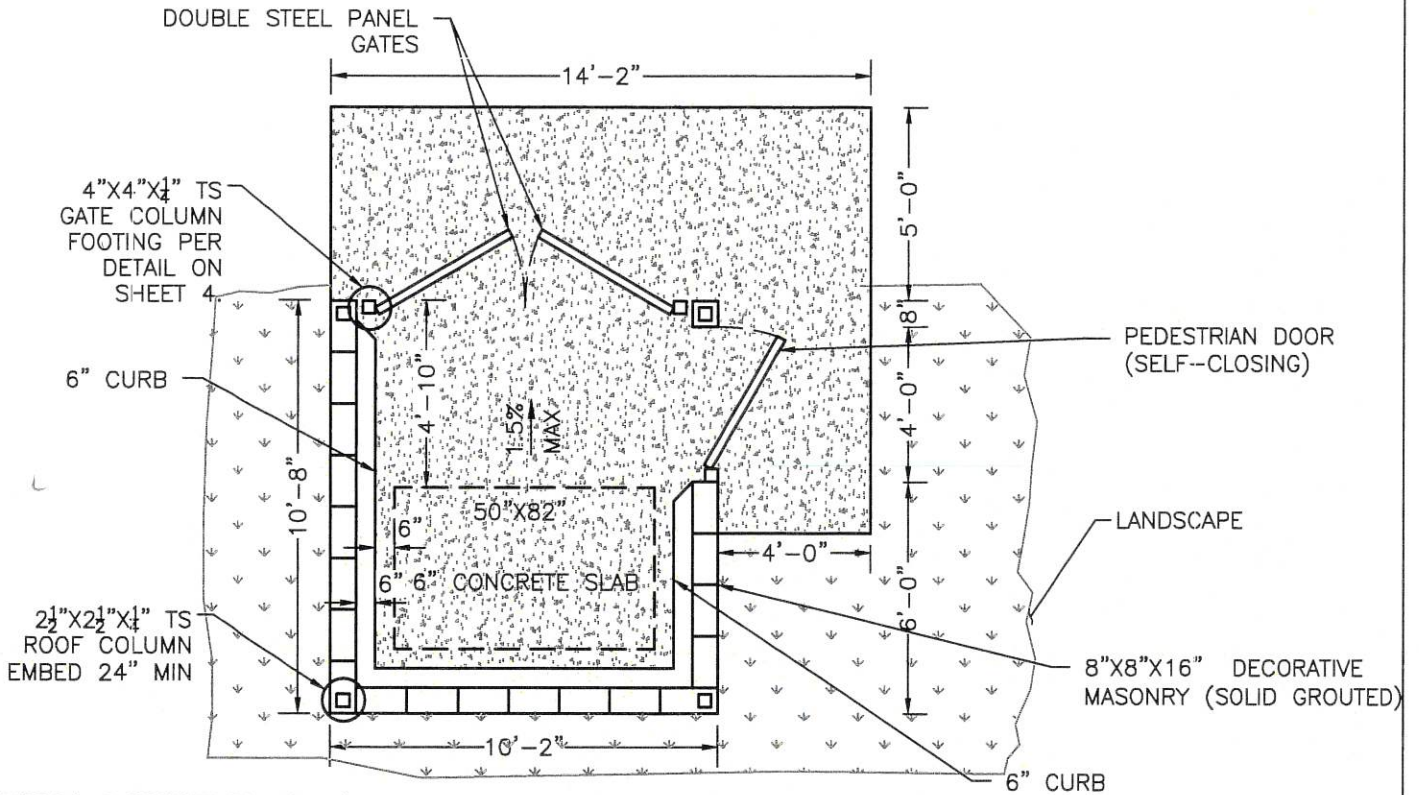

ENCLOSURE FOR DOUBLE BINS

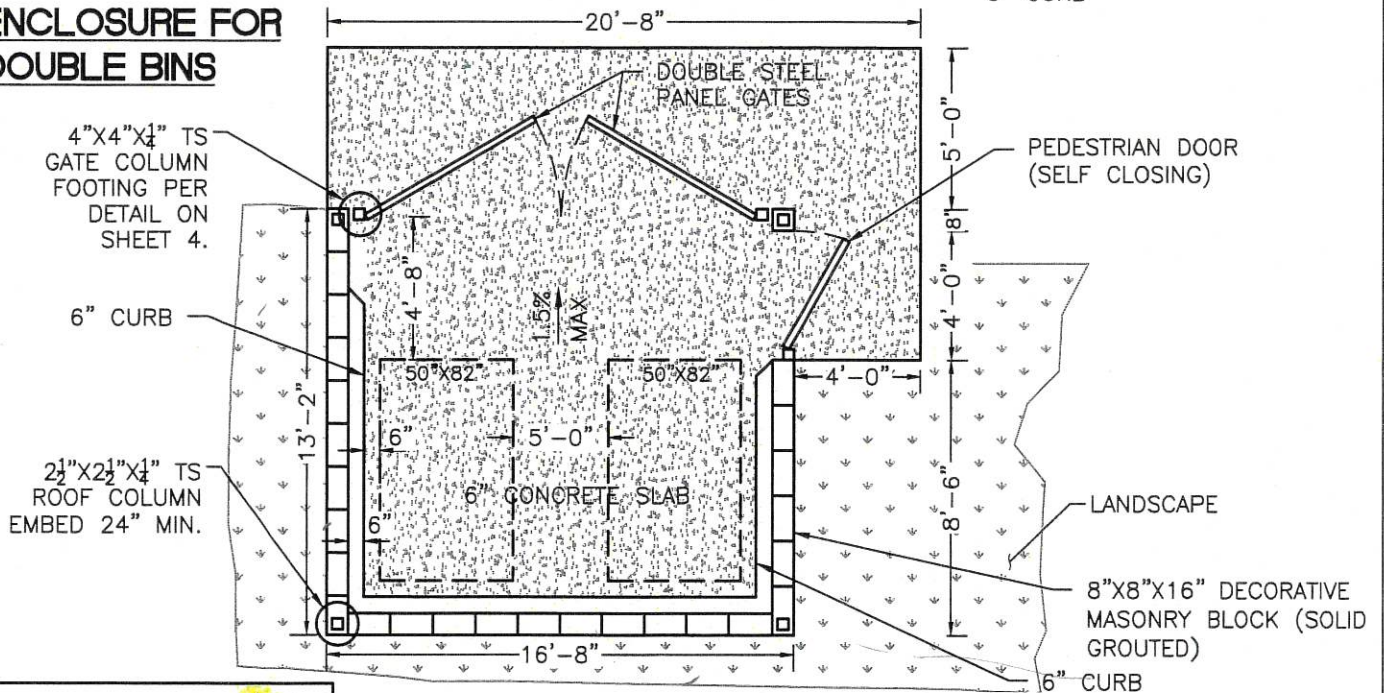

REVISION	NO:	BY:	DATE:
	1	DG	4/27/2023
	2	DG	1/13/2026

Drawn By: SG Date: 4/27/2023

APPROVED: *De J. [Signature]* 1/13/2026
CITY ENGINEER DATE

TRASH ENCLOSURE

Std. Dwg. No.
102
Sheet 1 of 9

CITY of SAN DIMAS STANDARD DRAWING

ENCLOSURE FOR TRIPLE BINS

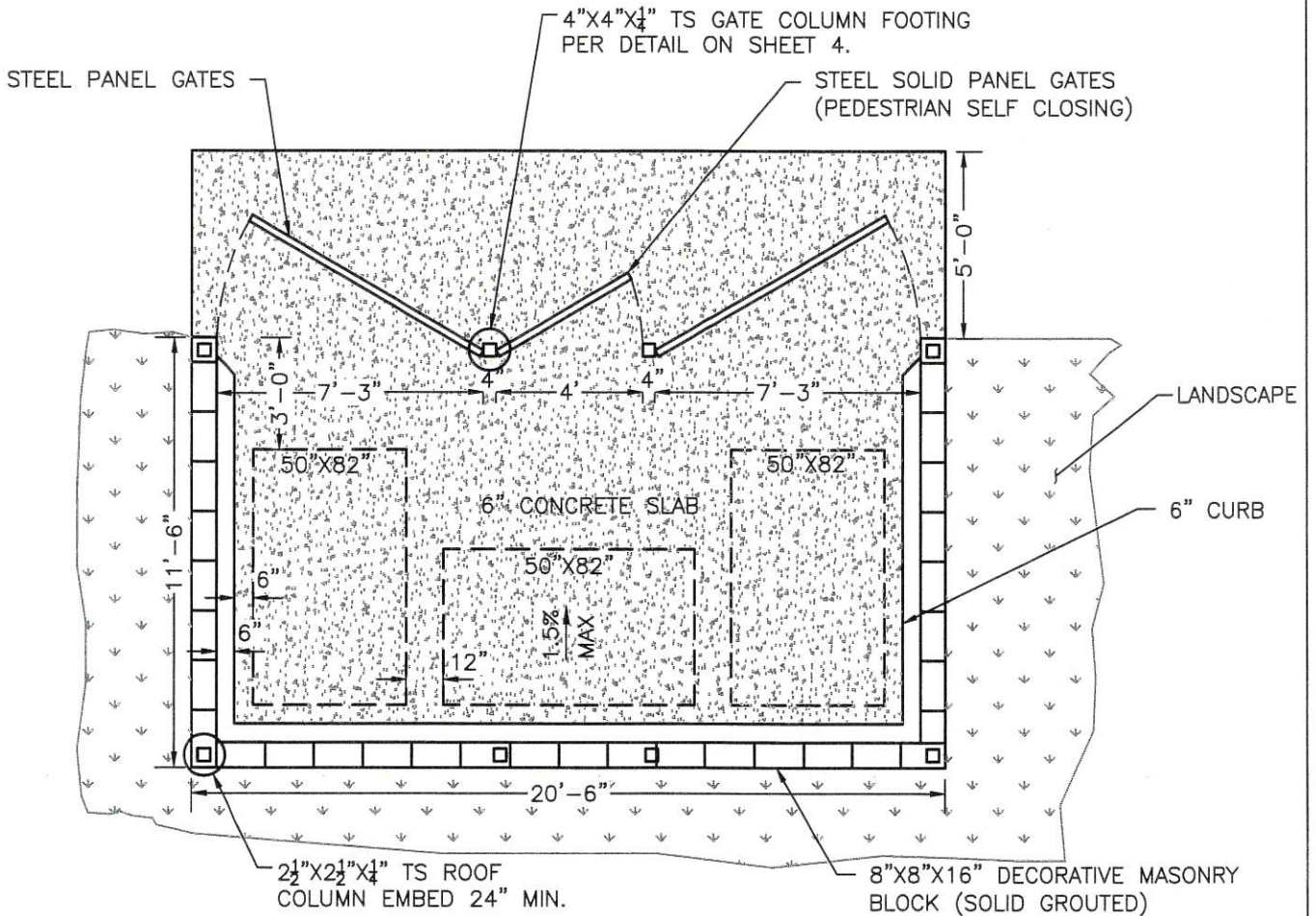

REVISION	NO:	BY:	DATE:
	1	DG	4/27/2023
	2	DG	1/13/2026

Drawn By: SG Date: 4/27/2023

APPROVED: *De J. J. [Signature]* 1/13/2026
 CITY ENGINEER DATE

TRASH ENCLOSURE (DETAILS)

Std. Dwg. No.
102
 Sheet 2 of 9

CITY of SAN DIMAS STANDARD DRAWING

3"X3" WOVEN WIRE MESH 10 GAUGE WITH 2½"X2"X¼"
ANGLE IRON FRAME (WELDED TO ROOF STRUCTURE AND
WALL WITH ¼"ØX5" RED HEAD @24" O.C.)

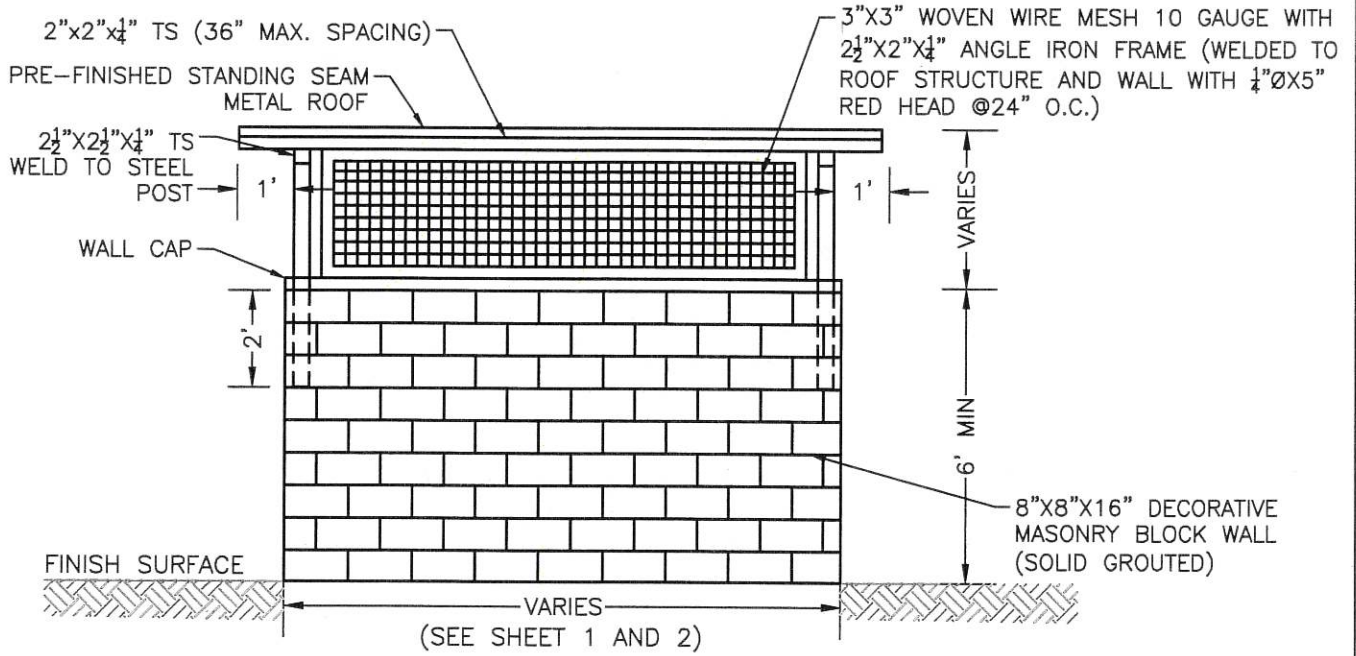
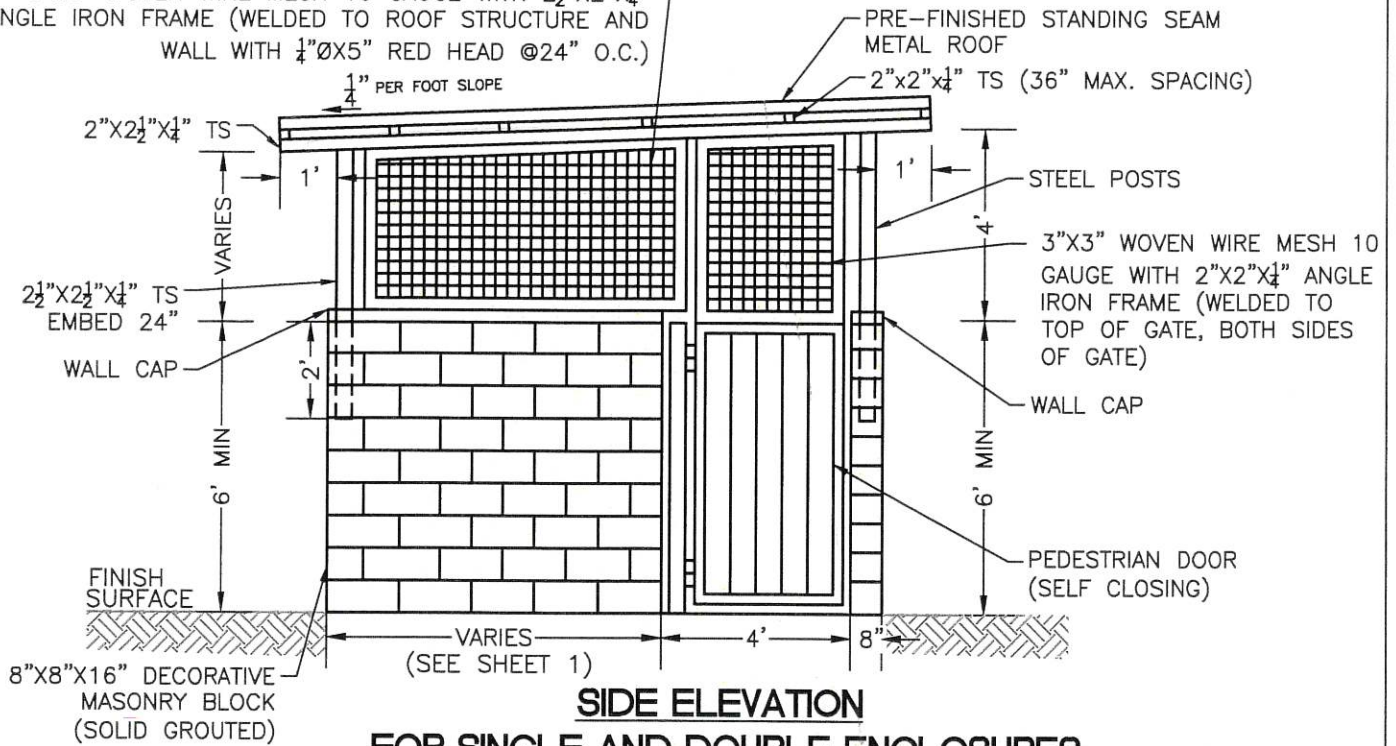

REVISION	NO:	BY:	DATE:
	1	DG	4/27/2023
	2	DG	1/13/2026

Drawn By: SG Date: 4/27/2023

APPROVED: *[Signature]* 1/13/2026
CITY ENGINEER DATE

TRASH ENCLOSURE (DETAILS)

Std. Dwg. No.
102
Sheet 3 of 9

CITY of SAN DIMAS STANDARD DRAWING

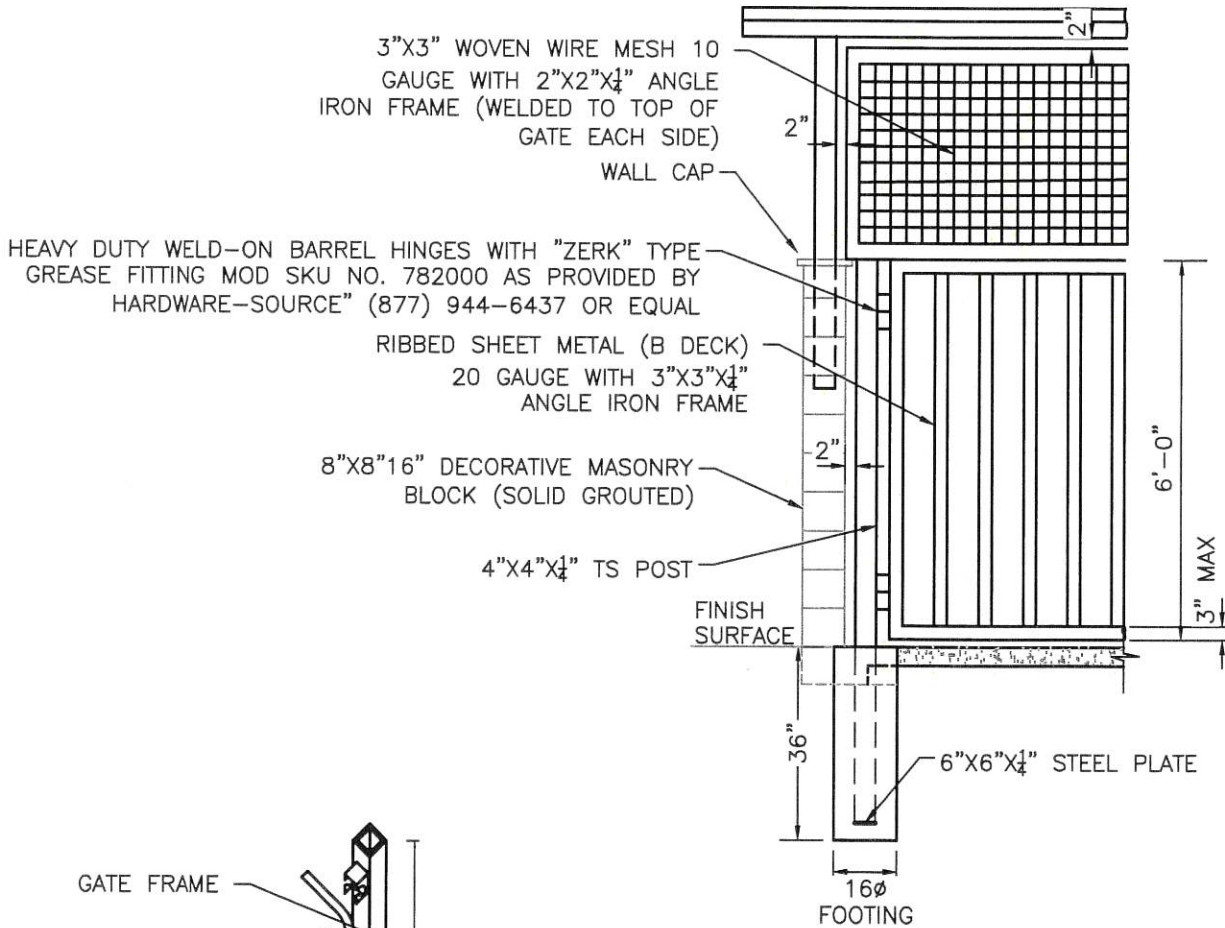

FOOTING AND GATE CONSTRUCTION

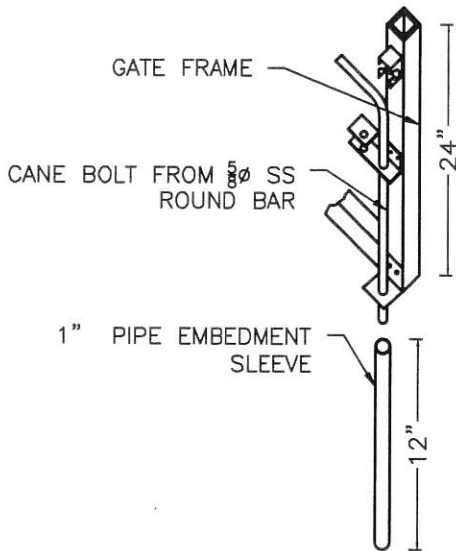

STOP BOLT DETAIL

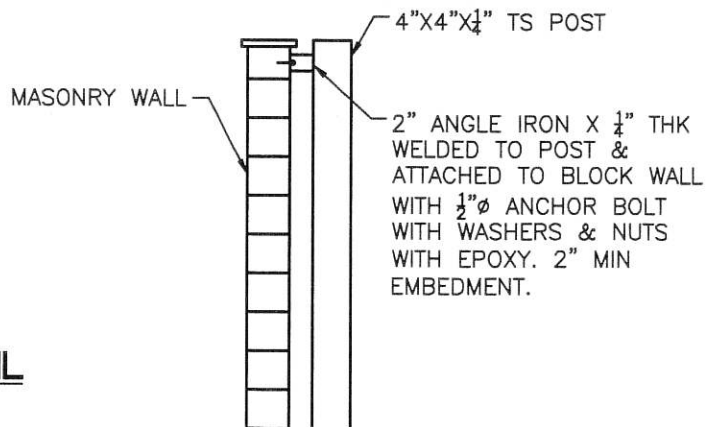

POST ATTACHMENT DETAIL



REVISION	NO:	BY:	DATE:
	1	DG	4/27/2023
	2	DG	1/13/2026

Drawn By: SG Date: 4/27/2023

APPROVED: *[Signature]* 1/13/2026
CITY ENGINEER DATE

TRASH ENCLOSURE (DETAILS)

Std. Dwg. No.
102
Sheet 4 of 9

CITY of SAN DIMAS STANDARD DRAWING

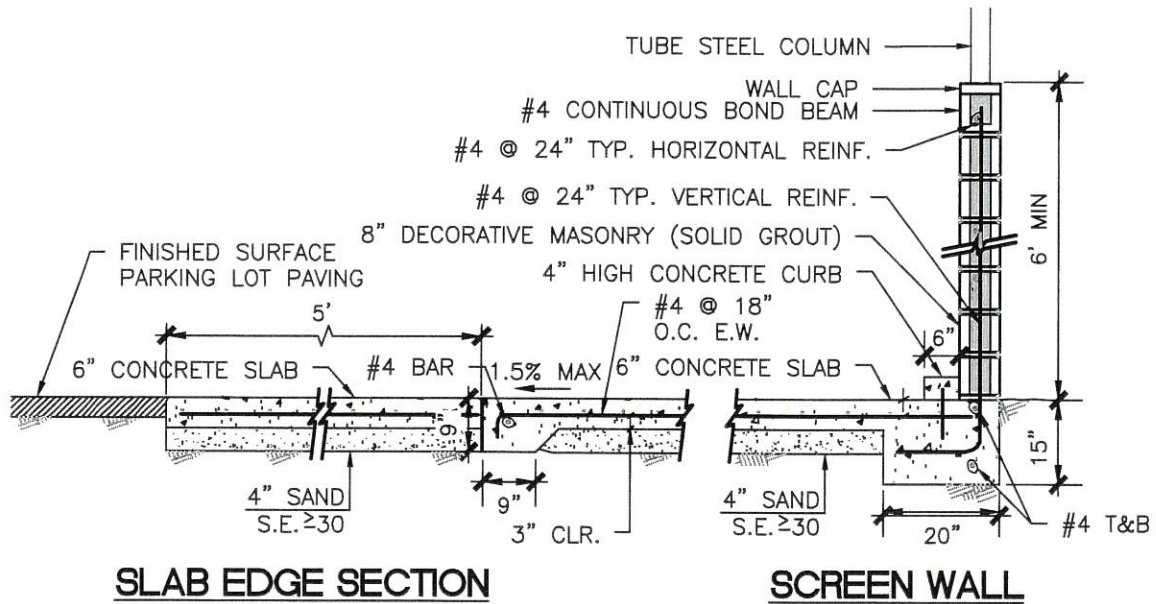

HEAVY DUTY WELD-ON BARREL HINGES WITH "ZERK" TYPE GREASE FITTING MOD SKU NO. 782000 AS PROVIDED BY HARDWARE-SOURCE" (877) 944-6437 OR EQUAL

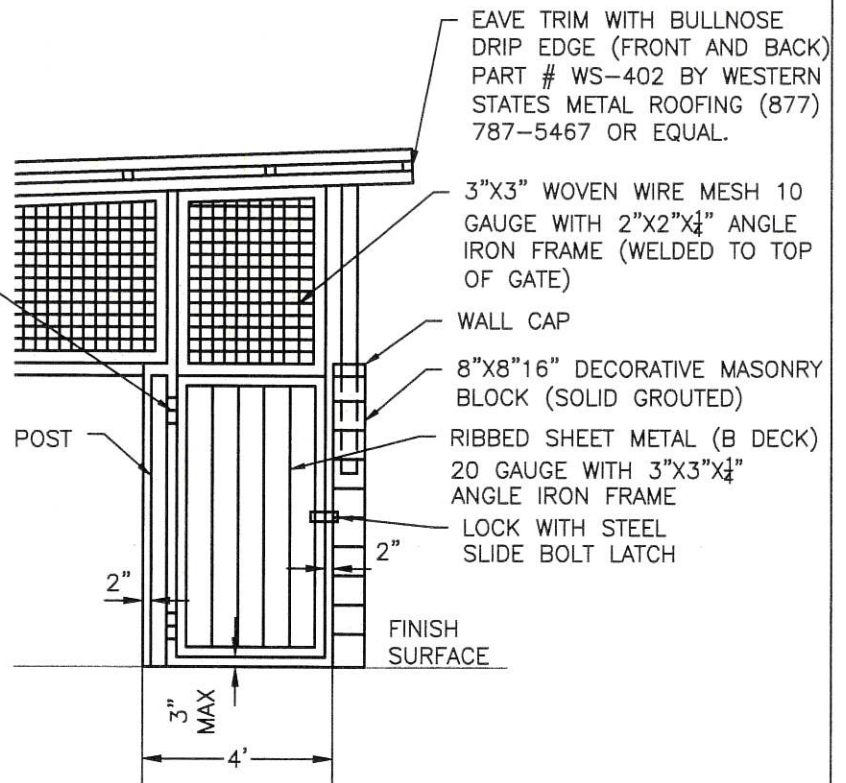

PEDESTRIAN GATE SELF-CLOSED

D&D SLIMLINE VERTICLE GATE CLOSER POST MOUNT - PULL SIDE (INSIDE MOUNT) MOD SKU NO. DNB-DCG22G POST-PULL-SIDE-L AS PROVIDED BY ALL SECURITY EQUIPMENT (800) 730-8382 OR EQUAL

PEDESTRIAN GATE DETAILS



REVISION	NO:	BY:	DATE:
	1	DG	4/27/2023
	2	DG	1/13/2026
Drawn By: SG		Date: 4/27/2023	

APPROVED:  1/13/2026
CITY ENGINEER DATE

TRASH ENCLOSURE (DETAILS)

Std. Dwg. No.
102
Sheet 5 of 9

CITY of SAN DIMAS STANDARD DRAWING

GENERAL NOTES

1. **WALLS:** CONCRETE MASONRY UNITS (C.M.U) SHALL BE SPLIT FACE, SLUMP STONE BLOCK, OR STUCCOED PRECISION BLOCK WITH PRE-CAST CONCRETE OR CULTURED STONE CAP. THE ARCHITECTURAL CONFIGURATION AND ELEVATION OF THE STRUCTURE TO BE APPROVED PRIOR TO CONSTRUCTION. WALLS SHALL BE A MINIMUM OF 6' IN HEIGHT.
2. **GATES:** SHALL BE RIBBED SHEET METAL (B DECK) 20 GAUGE WITH 3"x3"x $\frac{1}{4}$ " ANGLE IRON FRAME AND SHALL BE HUNG ON A 4"x4"x $\frac{1}{4}$ " TUBULAR STEEL POST, CONCRETE FILLED THAT IS NOT ATTACHED TO THE ENCLOSURE. GATES SHALL NOT OPEN INTO DRIVING LANES OR PARKING SPACES. GATES SHALL HAVE A MAXIMUM OF 2" GAP.
3. **SIZE:** ENCLOSURE SHALL MEET ONE OF OF THE SIZES SHOWN ON THIS PLAN, OTHER CONFIGURATIONS SHALL BE BASED ON THE PROPOSED USE AND SIZE OF THE FACILITY TO BE SERVED. FINAL CONFIGURATIONS AND SIZE SHALL MEET THE APPROVAL OF THE PLANNING DEPARTMENT.
4. **FLOOR:** SHALL BE A 6" REINFORCED CONCRETE SLAB OVER 4" SAND (S.E.≥30) WITH #4@18" O.C. EACH WAY, WITH A MAXIMUM SLOPE OF 1.5% TO DRAIN THE ENCLOSURE AND FLUSH WITH THE ADJOINING PARKING LOT PAVEMENT.
5. **LATCH:** A STAINLESS STEEL BARREL DOOR LATCH ASSEMBLY IS REQUIRED WITH CANE BOLTS ON ALL GATES TO HOLD IN CLOSED POSITION WITH 1" PIPE EMBEDMENT SLEEVE TO HOLD THE CANE BOLT.
6. **ROOF:** A SOLID ROOF IS REQUIRED ON ALL TRASH ENCLOSURES, WITH AN 10' VERTICAL CLEARANCE AT OPENING. SLOPE NOT TO DRAIN ACROSS PROPERTY LINES.
7. 6" CONCRETE CURB (WHEEL STOP), TYP. AT INSIDE PERIMETER.
8. SLIDE BOLT AND CANE BOLT PER DETAILS HEREIN.
9. ALL TS FENCING, GATES, POSTS, HARDWARE AND FITTINGS SHALL HAVE ONE COAT PRIMER AND TWO FINISH COATS OF RUST AND CORROSION RESISTANT ENAMEL PAINT. "SAN DIMAS BROWN" OR COLOR APPROVED BY THE PUBLIC WORKS DEPARTMENT.
10. ALL EXPOSED ENDS OR POSTS OR BRACES SHALL BE CAPPED OR PERMANENTLY SEALED TO PREVENT ENTRY OF WATER. NO PLASTIC CAPS ALLOWED.
11. STANDING SEAM METAL ROOF SHALL BE VERSA-SPAN BY TAYLOR METAL PRODUCTS WITH MEDIUM BRONZE COOL KYNAR 600 COATING.
12. WIRE MESH AND FRAME TO BE WELDED/MOUNTED TO TOP OF MASONRY, COLUMNS, AND BOTTOM OF ROOF STRUCTURE OR TO THE TOP OF THE GATE TO COMPLETELY ENCLOSE TRASH AREA.



REVISION	NO:	BY:	DATE:
	1	DG	4/27/2023
	2	DG	1/13/2026

Drawn By: SG Date: 4/27/2023

APPROVED:  1/13/2026
CITY ENGINEER DATE

TRASH ENCLOSURE (GENERAL NOTES)

Std. Dwg. No.
102
Sheet 6 of 9

CITY of SAN DIMAS STANDARD DRAWING

CONCRETE

1. ALL CONCRETE SHALL CONFORM TO THE LATEST EDITION OF THE CALIFORNIA BUILDING CODE AND ACI 318.
2. ALL CEMENT SHALL CONFORM TO ASTM C150. APPROPRIATE CEMENT TYPE AND CONCRETE STRENGTH SHALL BE SELECTED BASED ON EXPOSURE TO SOILS AND OR MATERIALS CAUSING SULFATE ATTACK PER CBC TABLE 1904.3.
3. FINE AND COARSE AGGREGATE SHALL CONFORM TO ASTM C33 FOR STANDARD WEIGHT CONCRETE AND ASTM C330 FOR LIGHT WEIGHT CONCRETE.
4. ANCHOR BOLTS, HOLDOWN BOLTS, DOWELS, INSERTS, ETC. SHALL BE SECURELY TIED IN PLACE PRIOR TO PLACING CONCRETE.
5. CONCRETE SHALL BE CURED BY KEEPING CONTINUOUSLY WET FOR 10-DAYS OR BY AN APPROVED CURING COMPOUND CONFORMING TO ASTM C1315, CLEAR TYPE I, CLASS A, WATERBORNE.
6. CONCRETE STRENGTHS:

 SLABS-ON-GRADE $f'_c=3,000$ PSI

 CONTINUOUS FOOTING AND PADS $f'_c=3,000$ PSI

 ALL CONCRETE SHALL REACH MINIMUM COMPRESSIVE STRENGTH AT 28 DAYS. PROVIDE CONCRETE MIX TO MEET ACI REQUIREMENTS FOR SULFATE EXPOSURE PER SOIL TYPE. FIELD VERIFY. NO SPECIAL INSPECTION REQUIRED.
7. CONCRETE FOR EXTERIOR SLABS ON GRADE SHALL HAVE A MINIMUM OF 4" OF SLUMP PER ASTM C143. MAXIMUM WATER TO CEMENT RATIO = 0.45. EXTERIOR SLABS TO BE DESIGNED FOR "SEVERE EXPOSURE" PER SECTION 4.2.1 OF ACI 318-11.

STRUCTURAL STEEL

1. ALL STRUCTURAL AND MISCELLANEOUS STEEL SHALL CONFORM TO THE LATEST EDITION OF THE AISC "SPECIFICATION FOR THE DESIGN, FABRICATION AND ERECTION OF STRUCTURAL STEEL FOR BUILDINGS" AND ALL ITS SUPPLEMENTS, AND TO THE AISC "CODE OF STANDARD PRACTICE FOR STEEL BUILDINGS AND BRIDGES."
2. ALL STRUCTURAL WIDE FLANG STEEL SHAPES SHALL HAVE A MIN. YIELD STRENGTH OF 50,000 PSI, UNLESS NOTED OTHERWISE.
3. ALL STRUCTURAL AND MISCELLANEOUS STEEL SHALL CONFORM TO ASTM-36 HAVING A MINIMUM YIELD STRENGTH OF 36,000 PSI. UNLESS NOTED OTHERWISE.
4. ALL CONNECTIONS, EXCEPT AS NOTED ON PLANS AND DETAILS, SHALL BE BOLTED OR WELDED CONNECTIONS AS SHOWN IN THE LATEST EDITION OF THE AISC MANUAL. ALL BEAM CONNECTIONS SHALL DEVELOP TO FULL UNIFORM LOAD CAPACITY THE MEMBER CAN CARRY WITH DUE CONSIDERATION TO CONCENTRATED LOADS AT THE ENDS OF THE MEMBER.



REVISION	NO:	BY:	DATE:
	1	DG	4/27/2023
	2	DG	1/13/2026

Drawn By: SG Date: 4/27/2023

APPROVED:  1/13/2026
CITY ENGINEER DATE

TRASH ENCLOSURE (GENERAL NOTES)

Std. Dwg. No.
102
Sheet 7 of 9

CITY of SAN DIMAS STANDARD DRAWING

STRUCTURAL STEEL (CONT.)

5. ALL BOLTED CONNECTIONS SHALL USE $\frac{3}{4}$ " ϕ MINIMUM ASTM A325 HIGH STRENGTH BOLTS, U.N.O. NO CONNECTION SHALL BE MADE USING LESS THAN TWO BOLTS.
6. ALL JOINTS OR CONTACT POINTS SHALL CONSIST OF CLEAR AND NEAT FILLET WELD AROUND ENTIRE CONTACT AREA. SPOT WELDS ARE NOT ACCEPTABLE. WELDING SHALL BE IN ACCORDANCE WITH THE LATEST EDITION OF THE "STRUCTURAL WELDING CODE", AWS D1.1 OF THE AMERICAN WELDING SOCIETY. ALL SHOP AND FIELD WELDING SHALL BE DONE BY CERTIFIED WELDERS QUALIFIED IN ACCORDANCE WITH AMERICAN WELDING SOCIETY STANDARDS. ALL WELDED CONNECTIONS SHALL BE PERFORMED USING E70XX ELECTRODES.
7. ALL ANCHOR BOLTS SHALL BE ASTM A-307. ANCHOR BOLT BOLT LENGTHS SHOWN ARE EMBEDDED LENGTHS.
8. STRUCTURAL STEEL TUBING SHALL BE ASTM A500.
9. SHOP PAINTING -ONE COAT RUSTOLEUM #678 OR EQUAL. PREPARATION FOR PAINTING SHALL CONFORM TO REQUIREMENTS OF SSPC-SP2.

MASONRY

1. ALL MASONRY CONSTRUCTION SHALL CONFORM TO THE CURRENT PROVISIONS OF THE BUILDING CODE REGULATIONS FOR MASONRY STRUCTURES - ACI 530(ASCE 5), AND SPECIFICATIONS FOR MASONRY STRUCTURES - ACI 530.1 (ASCE 6).
2. ASSUMED COMPRESSIVE STRENGTH OF MASONRY, $f'_m = 1350$ PSI @ 28 DAYS.
3. ALL CONCRETE MASONRY UNITS SHALL CONFORM TO ASTM C 90, GRADE N-1, NORMAL WEIGHT.
4. MORTAR FOR ALL WORK SHALL BE TYPE S.
5. GROUT FOR FILLING SHALL HAVE A MINIMUM COMPRESSIVE STRENGTH (f'_m) OF 2000 PSI, AND SHALL CONFORM TO ASTM C476. PLACE GROUT FILL IN 4'-0" MAXIMUM LIFTS VERTICALLY.
6. ALL REINFORCING BARS FOR REINFORCED MASONRY CONSTRUCTION SHALL CONFORM TO ASTM A-615 GRADE 40. LENGTH SHALL BE MINIMUM 40 BAR DIAMETERS.
7. ALL MASONRY SHALL BE DECORATIVE BLOCK OR STUCCO TO BE COORDINATED WITH SURROUNDING ARCHITECTURAL FEATURES.
8. WALL CAP TO BE DECORATIVE PRE-CAST CONCRETE OR CULTURED STONE CAP.
9. CMU WALLS TO BE SOLID GROUTED.



REVISION	NO:	BY:	DATE:
	1	DG	4/27/2023
	2	DG	1/13/2026

Drawn By: SG Date: 7/27/2022

APPROVED:  1/13/2026
CITY ENGINEER DATE

TRASH ENCLOSURE (GENERAL NOTES)

Std. Dwg. No.
102
Sheet 8 of 9

CITY of SAN DIMAS STANDARD DRAWING

REINFORCING STEEL

1. ALL REINFORNING SHALL BE ASTM A615, GRADE 40.
2. ALL BARS SHALL BE DEFORMED AS PER ASTM A305
3. ALL BARS SHALL BE CLEAN OF LOOSE FLAKY RUST, GREASE OR OTHER MATERIALS LIKELY TO IMPAIR BOND.
4. ALL BENDS SHALL BE MADE COLD.
5. SPLICING OF BARS SHALL HAVE LAPS OF 40 BAR DIAMETERS OR 2'-0" MINIMUM FOR ALL CONTINUOUS REINFORCEMENTS OF FOOTINGS AND CONCRETE WALLS, UNLESS OTHERWISE NOTED ON PLANS. MASONRY REINFORCEMENT SHALL HAVE LAPS OF 40 BAR DIAMETERS OF 2'-0", WHICHEVER IS GREATER.
6. ALL REINFORCEMENT BARS SHALL BE ACCURATELY AND SECURELY PLACED BEFORE PLACING CONCRETE.
7. CONCRETE PROTECTION FOR REINCEMENT SHALL BE AT LEAST EQUAL TO THE DIAMETER OF TH BARS. MINIMUM COVER SHALL BE AS FOLLOWS:
 - A. POURED AGAINST EARTH 3"
 - B. SLABS ON GRADE(FROM TOP OF SLAB) 1"
 - C. WALLS: -EXPOSED TO WEATHER 2"
 - NOT EXPOSED TO WEATHER #11 AND SMALLER 1"



REVISION	NO:	BY:	DATE:
	1	DG	4/27/2023
	2	DG	1/13/2026

Drawn By: SG Date: 7/27/2022

APPROVED:  1/13/2026
CITY ENGINEER DATE

TRASH ENCLOSURE (GENERAL NOTES)

Std. Dwg. No.
102
Sheet 9 of 9